

在使用缝纫机之前请阅读本使用说明书。
请将本使用说明书放在便于查阅的地方保管。



直驱高速平缝机 A9200L-D4-W-CP系列
DIRECT-DRIVE HIGH SPEED LOCKSTITCH SEWING MACHINE

零件手册

PARTS BOOK

浙江中捷缝纫科技有限公司
ZOJE SEWING MACHINE CO., LTD.

目 录

CONTENTS

零件样本 Parts Book

A	机壳分组件 Machine Frame & Miscellaneous Cover Components	1
B	上轴、挑线分组件 Main Shaft & Thread Take-up Cover Components	3
C	抬压脚分组件 Hang Lifter & Tension Release Components	5
D	勾线分组件 Hook Of Driving Shaft Components	9
E	送料分组件 Feed Mechanism Components	11
F	剪线分组件 Thread trimmer Components	15
G	润滑分组件 Lubrication Components	17
H	电控分组件 Drive-by-wire Components	19
I	过线架分组件 Components Of Thread-running Stand	21
J	附件 Auxiliaries	23

A

机壳分组件

Machine Frame & Miscellaneous Cover Components

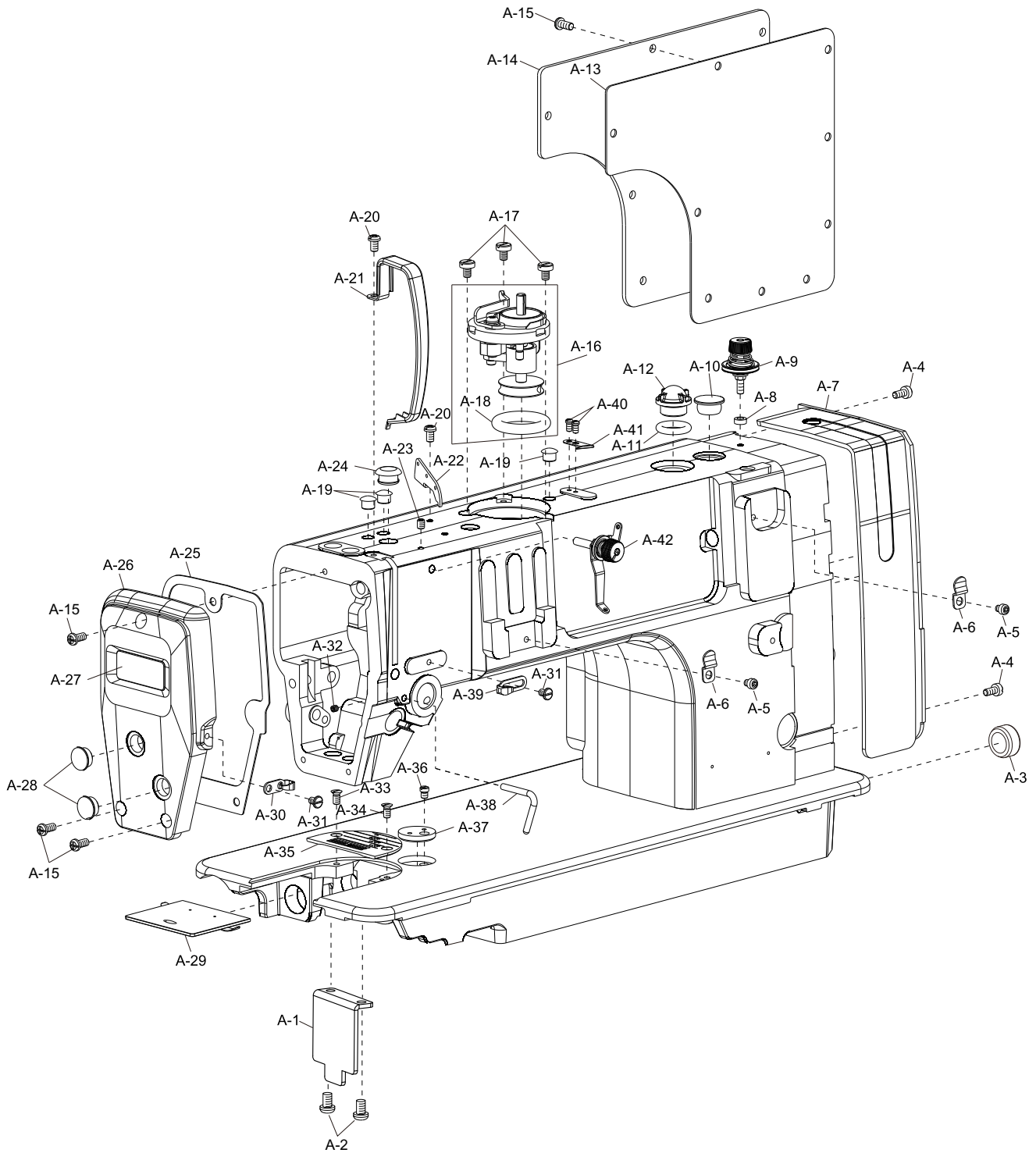

A

机壳分组件

Machine Frame & Miscellaneous Cover Components

序号 Ref. No.	件号 Part No.	名称	Name of part	数量 QTY	备注 Remark
A-1	10065750	前支撑板	Bed screw stud	1	
A-2	10012142	SM15/64" ×28螺钉	Screw SM15/64" ×28	2	
A-3	10040969	橡胶塞	Rubber plug	1	
A-4	10010066	SM11/64"×40螺钉	Screw SM11/64"×40	2	
A-5	10003382	SM11/64"×40螺钉	Screw SM11/64"×40	2	
A-6	10062047	滑扣簧	Slide buckle	2	
A-7	10067450	塑料标识板	Plastic plate	1	
A-8	10062565	绕线夹线器垫圈	Washer	1	
A-9	10062049	绕线夹线器组件	Bobbin thread tension ASM	1	
A-10	10009576	橡胶塞	Rubber plug	1	
A-11	10008938	油窗	Oil window	1	
A-12	10008939	19×3 O形圈	O-ring 19×3	1	
A-13	10066540	后窗板垫	Side plate gasket	1	
A-14	20025957	后窗板	Side plate	1	
A-15	10008972	SM3/16" ×28螺钉	Screw SM3/16" ×28	12	
A-16	10031086	绕线器	Bobbin wider ASM.	1	
A-17	10004380	SM3/16" ×32螺钉	Screw SM3/16" ×32	3	
A-18	10008773	橡胶轮	Rubber ring	1	
A-19	10008943	橡胶塞	Rubber ring	3	
A-20	10008934	SM3/16" ×28螺钉	Screw SM3/16" ×28	2	
A-21	20027103	挑线杆护罩	Thread take-up lever cover	1	
A-22	10052992	过线板	Thread tension guide	1	
A-23	10041529	SM3/16" ×28螺钉	Screw SM3/16" ×28	1	
A-24	10008942	橡胶塞	Rubber ring	1	
A-25	10062031	面板垫	Face plate gasket	1	
A-26	20024053	面板	Face plate	1	
A-27	*	面板装饰牌	Decorative board	1	
A-28	10008977	橡胶塞	Rubber ring	2	
A-29	10013706	推板部件	Push plate ASM.	1	
A-30	10008937	左线钩	Arm thread guide left	1	
A-31	10008973	SM11/64"×40螺钉	Screw SM11/64"×40	2	
A-32	10009074	M4螺钉	Screw M4	1	
A-33	10012463	SM11/64" ×40螺钉	Screw SM11/64" ×40	1	
A-34	10009005	SM11/64" ×40螺钉	Screw SM11/64" ×40	1	
A-35	10060708	针板组件	Needle plate	1	
	10014459	针板组件	Needle plate	1	-5
	10052350	针板组件	Needle plate	1	S7/H
A-36	10004374	SM11/64" ×40螺钉	Screw SM11/64" ×40	1	
A-37	10068607	限位挡片	Ruler plate	1	
A-38	10038945	缓线钩	Presser bar thread guide	1	
A-39	10008940	右线钩	Arm thread guide right	1	
A-40	10050423	SM9/64"×40螺钉	Screw SM9/64"×40	2	
A-41	10011149	绕线切刀	Thread cutter	1	
A-42	10070942	上夹线器部件	Top thread tension ASM	1	

“*” 具体料号需向客服咨询

“*” Specific content need to consult customer service

B

上轴、挑线分组件

Main Shaft & Thread Take-up Cover Components

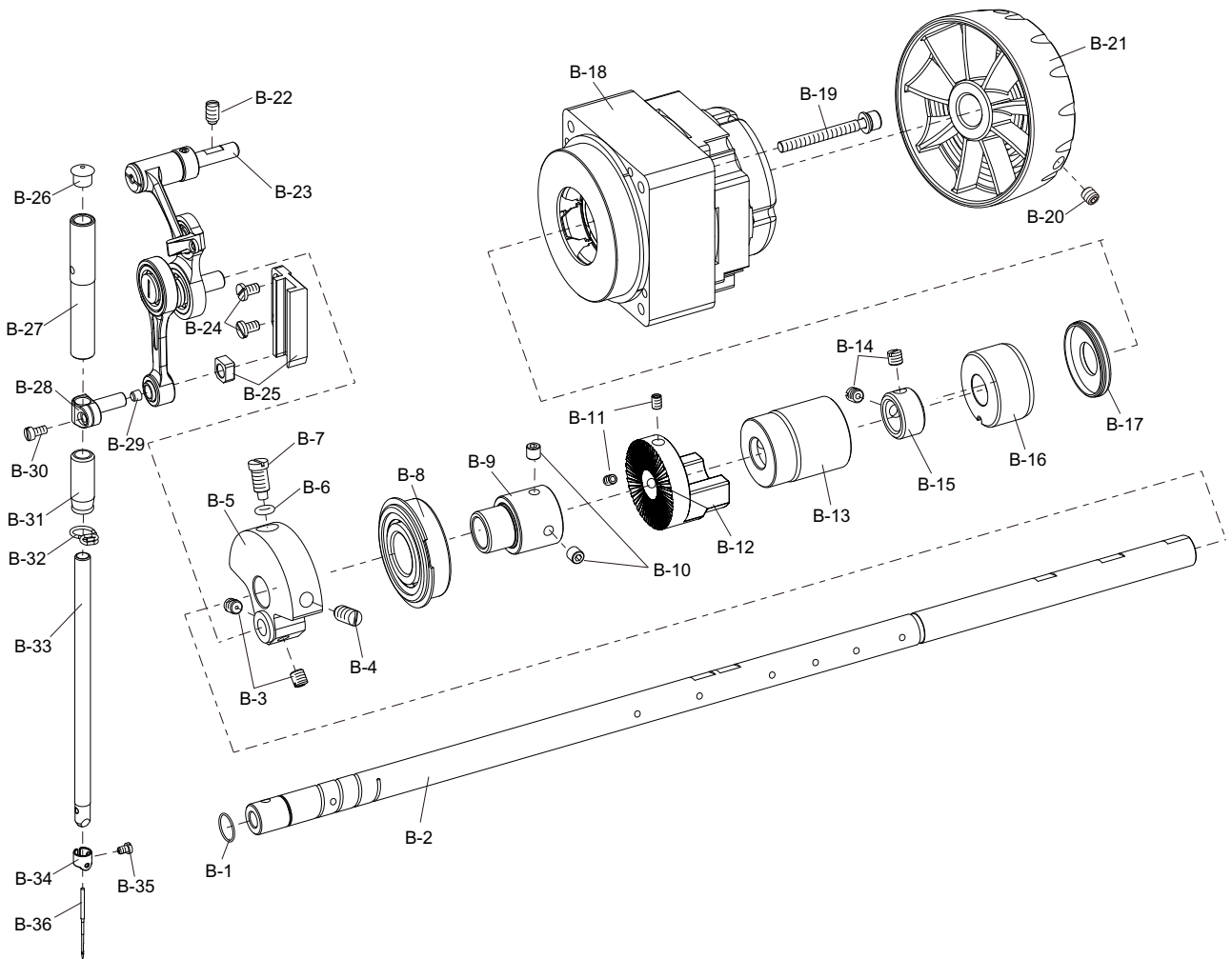

B

上轴、挑线分组件

Main Shaft & Thread Take-up Cover Components

序号 Ref. No.	件号 Part No.	名称	Name of part	数量 QTY	备注 Remark
B-1	10008886	12.2×0.8 O型圈	O-ring 12.2×0.8	1	
B-2	10064223	上轴	Main shaft	1	
B-3	10010065	SM1/4"×40螺钉	Screw SM1/4"×40	2	
B-4	10010082	SM9/32"×28螺钉	Screw SM9/32"×28	1	
B-5	10008850	针杆曲柄	Counter weight	1	
B-6	10010534	9.2×2.4O形圈	O-ring 9.2×2.4	1	
B-7	10010545	SM9/32"×28螺钉	Screw SM9/32"×28	1	
B-8	10003578	6204ZZNR轴承	Bearing	1	
B-9	10059928	轴承套	Shaft sleeve	1	
B-10	10000881	SM1/4"×40螺钉	Screw SM1/4"×40	2	
B-11	10041529	SM11/64"×40螺钉	Screw SM11/64"×40	2	
B-12	10062836	绕线主动轮	Driving wheel	1	
B-13	10058166	上轴中轴套	Shaft sleeve	1	
B-14	10005020	SM1/4"×40螺钉	Screw SM1/4"×40	2	
B-15	10051571	上轴挡圈	Thrust collar	1	
B-16	10059929	上轴后轴套	Shaft sleeve	1	
B-17	10062629	32×15油封	Oil seal 32×15	1	
B-18	10068155	琦星步进分体电机	Motor	1	
B-19	10059025	M5螺钉组件	Screw ASM. M5	4	
B-20	10009187	M6×8螺钉	Screw M6×8	2	
B-21	20023713	上轮	Head wheel	1	
B-22	10010083	SM15/64"×28螺钉	Screw SM15/64"×28	1	
B-23	10052994	挑线杆组件	Thread take-up lever ASM.	1	
B-24	10043360	SM11/64"×40螺钉	Screw SM11/64"×40	2	
B-25	10054365	导轨滑块组件	Guide & Slider	1	
B-26	10010587	橡胶塞	Rubber plug	1	
B-27	10053132	针杆上轴套	Shaft sleeve	1	
B-28	10059132	针杆连接柱	Needle bar holder	1	
B-29	10008864	橡胶塞	Rubber plug	1	
B-30	10030286	SM9/64"×40螺钉	Screw SM9/64"×40	1	
B-31	10008955	针杆下轴套	Shaft sleeve	1	
B-32	10005943	针杆下轴套线钩	Needle bar thread guide	1	
B-33	10063561	针杆	Needle bar	1	
B-34	10010591	针杆过线环	Needle bar thread guide	1	
B-35	10010588	SM1/8"×40螺钉	Screw SM1/8"×40	1	
B-36	*	DB×1 14#机针	Needle Db×1 14#	1	

“*” 具体料号需向客服咨询
 “**” Specific content need to consult customer service



抬压脚分组件 Hang Lifter & Tension Release Components

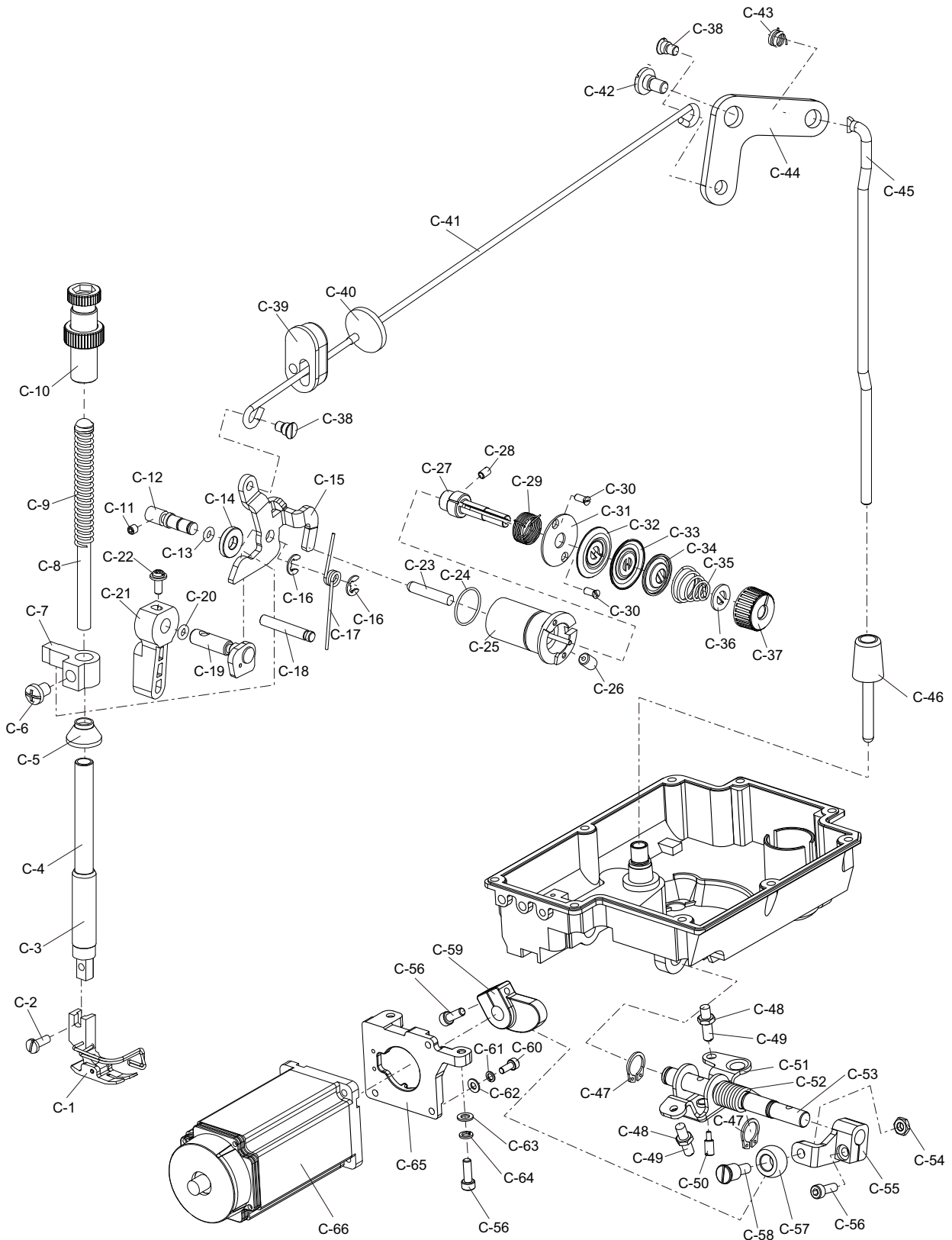



抬压脚分组件
Hang Lifter & Tension Release Components

序号 Ref. No.	件号 Part No.	名称	Name of part	数量 QTY	备注 Remark
C-1	10052532	压脚组件	Presser foot ASM.	1	
C-2	10010650	SM9/64" ×40螺钉	Screw SM9/64" ×40	1	
C-3	10010646	压杆	Presser bar	1	
C-4	10005915	压杆轴套	Shaft sleeve	1	
C-5	10011457	压杆防油罩	Oil protector cover	1	
C-6	10000325	M6×8螺钉	Screw M6×8	1	
C-7	10039365	压杆导架	Presser guide bar bracket	1	
C-8	10004439	调压导杆	Presser guide bar	1	
C-9	10004473	调压弹簧	Spring	1	
C-10	10062052	调压螺钉组件	Screw ASM.	1	
C-11	10009074	M4×4螺钉	Screw M4×4	1	
C-12	10039373	松线顶板销	Pin	1	
C-13	10010027	3.68×1.78 O形圈	O-ring 3.68×1.78	1	
C-14	10051244	6.2×15×2.7垫片	Gasket 6.2×15×2.7	1	
C-15	10058058	压脚升降板	Lifting lever	1	
C-16	10013038	5×0.8挡圈	Closing ring 5×0.8	2	
C-17	10052046	压脚升降板复位簧	Spring	1	
C-18	10039374	限位销	Pin	1	
C-19	10050190	压脚扳手凸轮部件	Hand lifter CAM ASM.	1	
C-20	10010027	3.68×1.78 O形圈	O-ring 3.68×1.78	1	
C-21	10062023	压脚扳手	Hand lifter	1	
C-22	10010016	SM9/64"×40螺钉	Screw SM11/64"×40	1	
C-23	10058060	松线辅钉	Tension release supporting pin	1	
C-24	10053484	17×1 O形圈	O-ring 17×1	1	
C-25	10064221	松线电磁铁	Electromagnetic	1	
C-26	10010678	SM15/64"×28螺钉	Screw SM15/64"×28	1	
C-27	10037581	夹线螺钉	Screw	1	
C-28	10002896	M4×5螺钉	Screw M4×5	1	
C-29	10053259	挑线弹簧	Spring	1	
C-30	10010399	SM3/32"×56螺钉	Screw SM3/32"×56	2	
C-31	10051910	锁紧板	Lock plate	1	
C-32	10005489	过线板	Thread tension disk	1	
C-33	10005489	过线板	Thread tension disk	1	
C-34	10004625	松线板	Thread tension disk presser	1	
C-35	10004176	弹簧	Spring	1	
C-36	10004199	夹线制动板	Rotating stopper	1	
C-37	10062024	松线器螺母	Thread tension nut	1	
C-38	10010651	SM3/16"×32螺钉	Screw SM3/16"×32	2	
C-39	10059957	橡胶塞	Rubber plug	1	
C-40	10053351	隔油罩	Oil shield	1	
C-41	10068925	抬压脚拉杆	Lifting lever connecting rod	1	
C-42	10010652	后杠杆轴位螺钉	Screw	1	
C-43	10009205	弹簧	Spring	1	
C-44	10010017	抬压脚后杠杆	Lifting lever link	1	
C-45	10067486	抬压脚顶杆	Connecting rod vertical	1	
C-46	10068362	膝提顶杆	Knee lift rod	1	
C-47	10063385	轴用弹性挡圈	Retaining ring	2	



抬压脚分组件
Hang Lifter & Tension Release Components

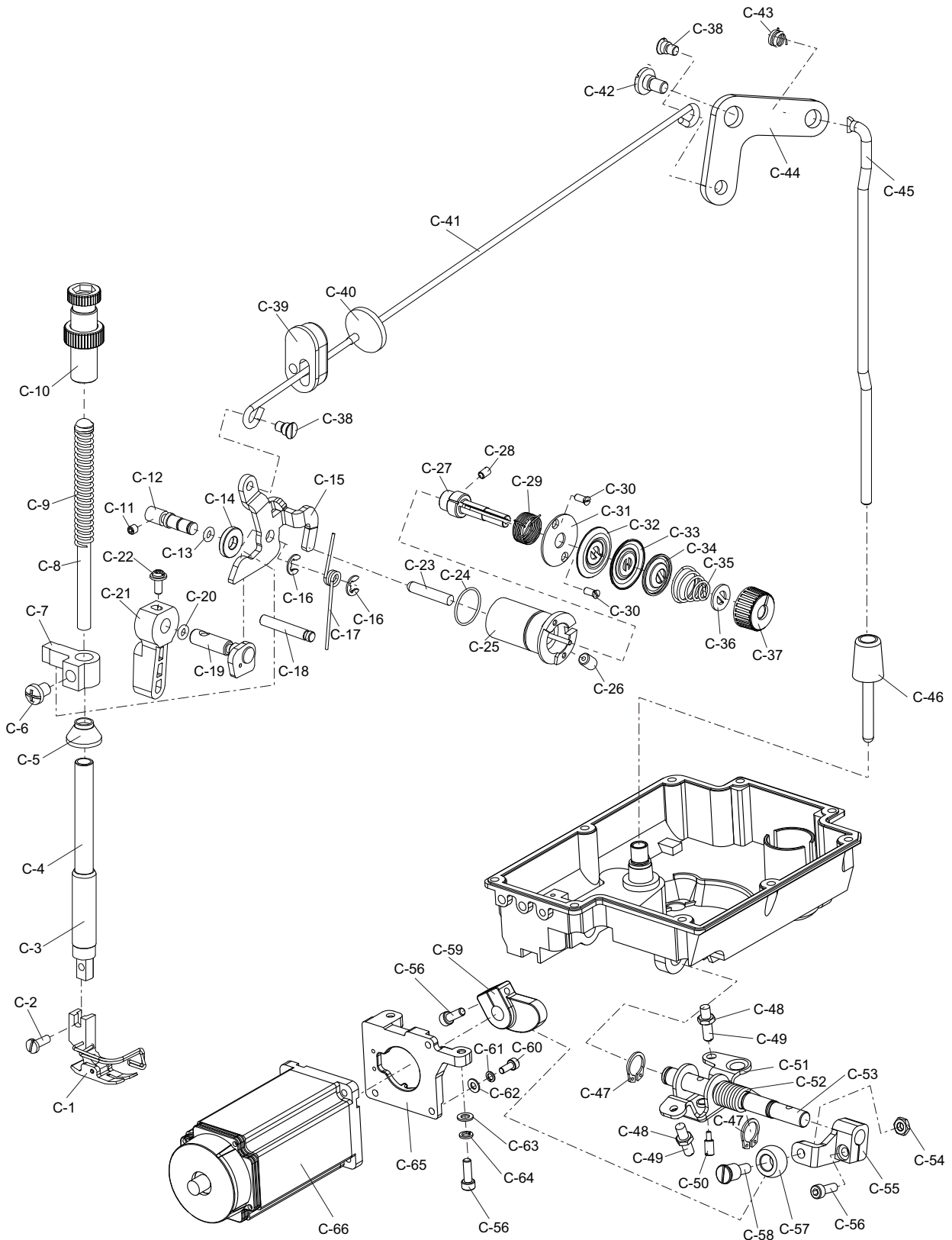

**抬压脚分组件****Hang Lifter & Tension Release Components**

序号 Ref. No.	件号 Part No.	名称	Name of part	数量 QTY	备注 Remark
C-48	10061673	M6×22螺钉	Screw M6×22	2	
C-49	10003890	M6×3.2螺母	Nut M6×3.2	2	
C-50	10058784	螺钉	Screw	1	
C-51	10059960	抬压脚双向曲柄	Two-way crank of lifting pressor foot	1	
C-52	10059959	弹簧	Spring	1	
C-53	10065730	抬压脚轴	Lifting shaft	1	
C-54	10001997	M6螺母	Nut M6	1	
C-55	10067536	抬压块	Crank	1	
C-56	10000980	M5×14螺钉	Screw M5×14	5	
C-57	10068581	滚柱	Roller	1	
C-58	10068583	滚柱螺钉	Screw	1	
C-59	10067535	抬压凸轮	Cam	1	
C-60	10014395	M4×14螺钉	Screw M4×14	3	
C-61	10009503	弹簧垫圈 4	Gaskets 4	3	
C-62	10002954	平垫圈 4	Gaskets 4	3	
C-63	10006115	平垫圈 5	Gaskets 5	2	
C-64	10005537	弹簧垫圈 5	Gaskets 5	2	
C-65	10067540	安装板	Plate	1	
C-66	10065763	剪线抬压脚电机	Motor	1	

D

勾线分组件 Hook Of Driving Shaft Components

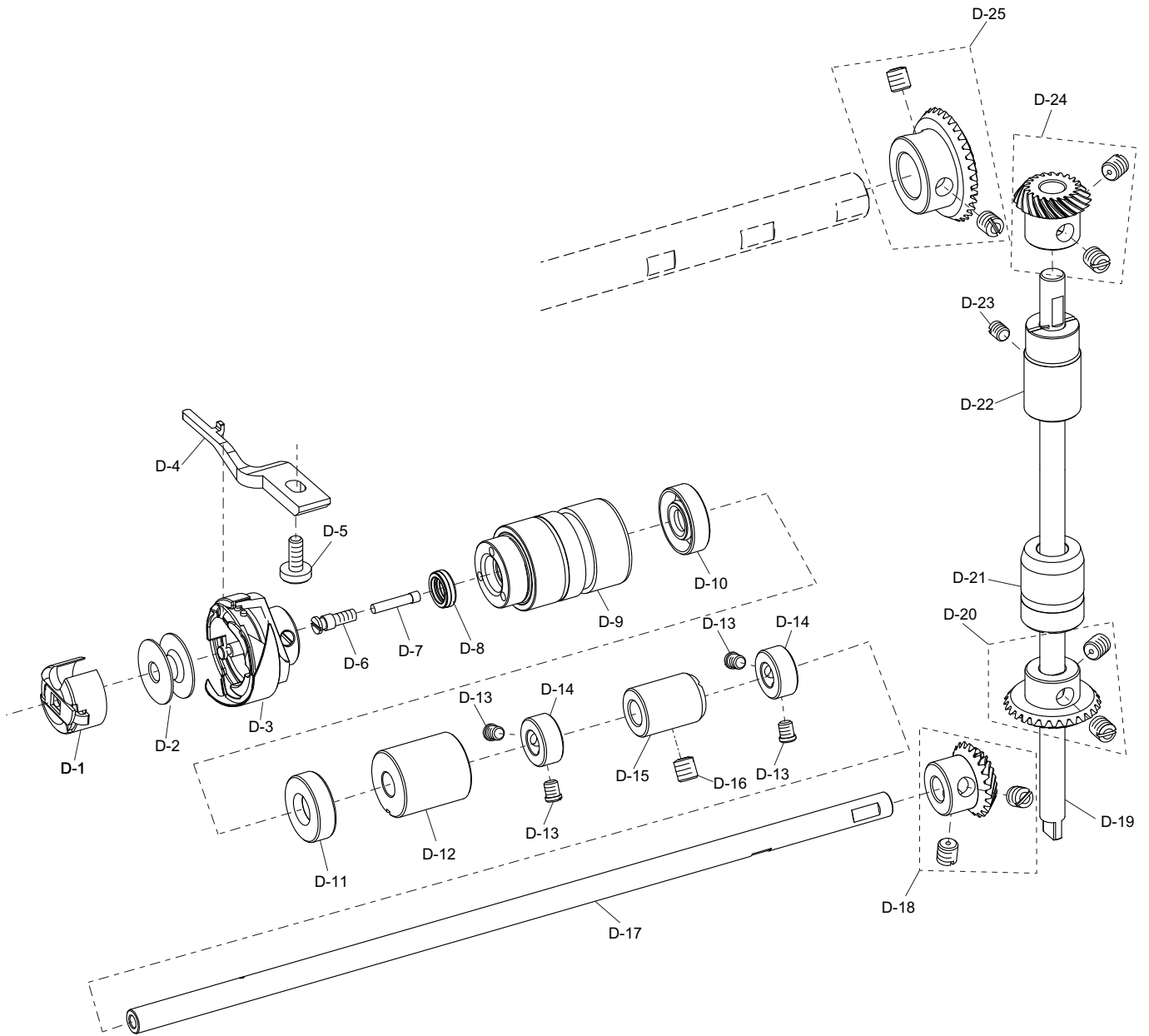

D

勾线分组件
Hook Of Driving Shaft Components

序号 Ref. No.	件号 Part No.	名称	Name of part	数量 QTY	备注 Remark
D-1	*	梭壳	Bobbin case	1	
D-2	10025484	梭芯	Bobbin	1	
D-3	*	旋梭	Hook	1	
D-4	10061669	旋梭定位钩	Positioning finger	1	
D-5	10011101	SM11/64"×40螺钉	Screw SM11/64"×40	1	
D-6	10010064	下轴限油螺钉	Screw	1	
D-7	10010063	油芯	Oil wick	1	
D-8	10013029	7.94×12×3.5油封	Oil sealing 7.94×12×3.5	1	
D-9	10058168	下轴前轴套	Shaft sleeve	1	
D-10	10014503	7.94×22×6.5油封	Oil sealing 7.94×22×6.5	1	
D-11	10014503	7.94×22×6.5油封	Oil sealing 7.94×22×6.5	1	
D-12	10058278	下轴中轴套	Shaft sleeve	1	
D-13	10012062	SM11/64"×40螺钉	Screw SM11/64"×40	4	
D-14	10058173	挡圈	Thrust collar	2	
D-15	10063444	下轴后轴套	Shaft sleeve	1	
D-16	10041529	SM3/16"×28螺钉	Screw SM3/16"×28	1	
D-17	10064224	下轴	Hook driving shaft	1	
D-18	10002560	下轴伞齿轮组件	Gear ASM.	1	
D-19	10058174	竖轴	Upright shaft	1	
D-20	10002509	竖轴下伞齿轮组件	Gear ASM.	1	
D-21	10007235	竖轴下轴套	Shaft sleeve	1	
D-22	10007267	竖轴上轴套	Shaft sleeve	1	
D-23	10041529	SM3/16"×28螺钉	Screw SM3/16"×28	1	
D-24	10002561	竖轴上伞齿轮	Gear	1	
D-25	10002445	上轴伞齿轮组件	Gear ASM.	1	

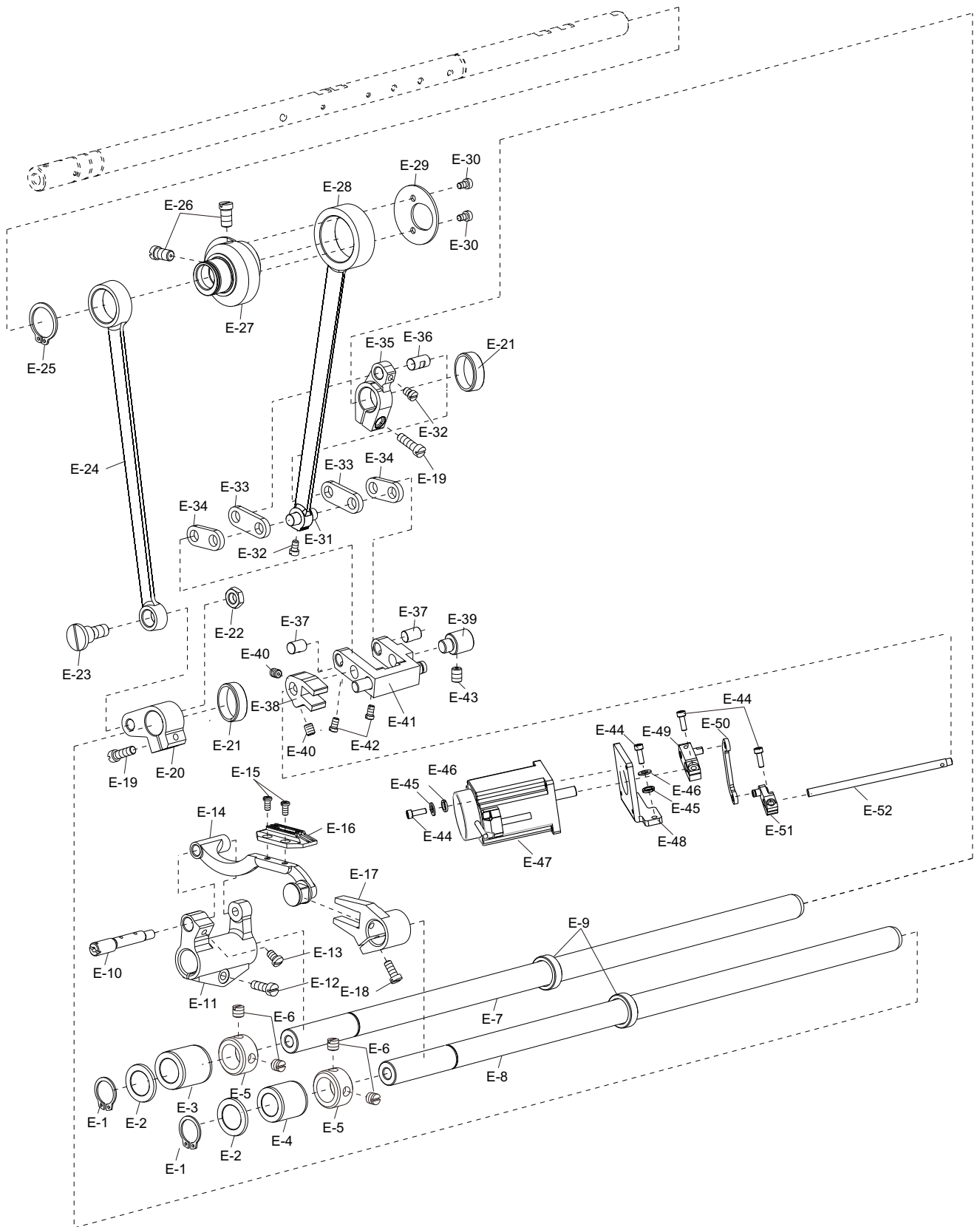

E

送料分组件
Feed Mechanism Components

序号 Ref. No.	件号 Part No.	名称	Name of part	数量 QTY	备注 Remark
E-1	10010090	13.8×1挡圈	Closing ring 13.8×1	2	
E-2	10058066	垫圈	Washer	2	
E-3	10058169	送料轴前套	Shaft sleeve	1	
E-4	10067616	拾牙轴前套	Shaft sleeve	1	
E-5	10010542	挡圈	Thrust collar	2	
E-6	10038073	SM1/4"×40螺钉	Screw SM1/4"×40	4	
E-7	10064226	送料轴	Feed driving shaft	1	
E-8	10064225	拾牙轴	Feed driving shaft	1	
E-9	10012536	14.72×22×7油封	Oil seal 14.72×22×7	2	
E-10	10061663	销	Pin	1	
E-11	10061662	牙架座	Feed bar driving crank	1	
E-12	10004993	SM3/16"×28螺钉	Screw SM3/16"×28	1	
E-13	10010074	SM11/64"×40螺钉	Screw SM11/64"×40	1	
E-14	10069423	牙架部件	Feed bar ASM.	1	
E-15	10010099	SM1/8"×44螺钉	Screw SM1/8"×44	2	
E-16	10056721	送料牙	Feed dog	1	
	10026357	送料牙	Feed dog	1	S7
	10007322	送料牙	Feed dog	1	-5
	10038413	送料牙	Feed dog	1	H
E-17	10010100	拾牙叉形曲柄	Crank	1	
E-18	10004628	SM11/64"×40螺钉	Screw SM11/64"×40	1	
E-19	10010095	SM3/16"×28螺钉	Screw SM3/16"×28	2	
E-20	10010086	拾牙后曲柄	Crank	1	
E-21	10054363	橡胶塞	Rubber plug	2	
E-22	10004475	SM9/32"×28螺母	Nut SM9/32"×28	1	
E-23	10051856	拾牙连杆轴位螺钉	Screw	1	
E-24	10010084	拾牙连杆	Connecting rod	1	
E-25	10010089	18.5×1.2挡圈	Closing ring 18.5×1.2	1	
E-26	10010092	SM1/4"×40螺钉	Screw SM1/4"×40	2	
E-27	10010115	送料偏心轮	Feed drive eccentric cam	1	
	10005991	送料偏心轮	Feed drive eccentric cam	1	S7/H
E-28	10010072	送料连杆	Connecting rod	1	
	10006004	送料连杆	Connecting rod	1	S7/H
E-29	10010098	送料偏心轮盖板	Thrust cover	1	
	10005992	送料偏心轮盖板	Thrust cover	1	S7/H
E-30	10010643	SM9/64"×40螺钉	Screw SM9/64"×40	2	
E-31	10010069	销	Pin	1	
E-32	10010071	SM9/64"×40螺钉	Screw SM9/64"×40	2	
E-33	10010068	送料长摆动板	Connecting plate	2	
E-34	10010075	送料短摆动板	Connecting plate	2	
E-35	10010076	送料曲柄	Crank	1	
E-36	10010096	送料曲柄销	Pin	1	
E-37	10010087	短摆动板连接销	Pin	2	
E-38	10058082	倒缝驱动曲柄	Crank	1	
E-39	10058084	送料摆动板座左右销	Pin	1	
E-40	10011232	螺钉-SM3/16"×28	Screw SM3/16"×28	2	
E-41	10058081	送料摆动板座部件	Feed adjusting ASM.	1	

"*" 具体内容需向客服咨询

"*" Specific content need to consult customer service

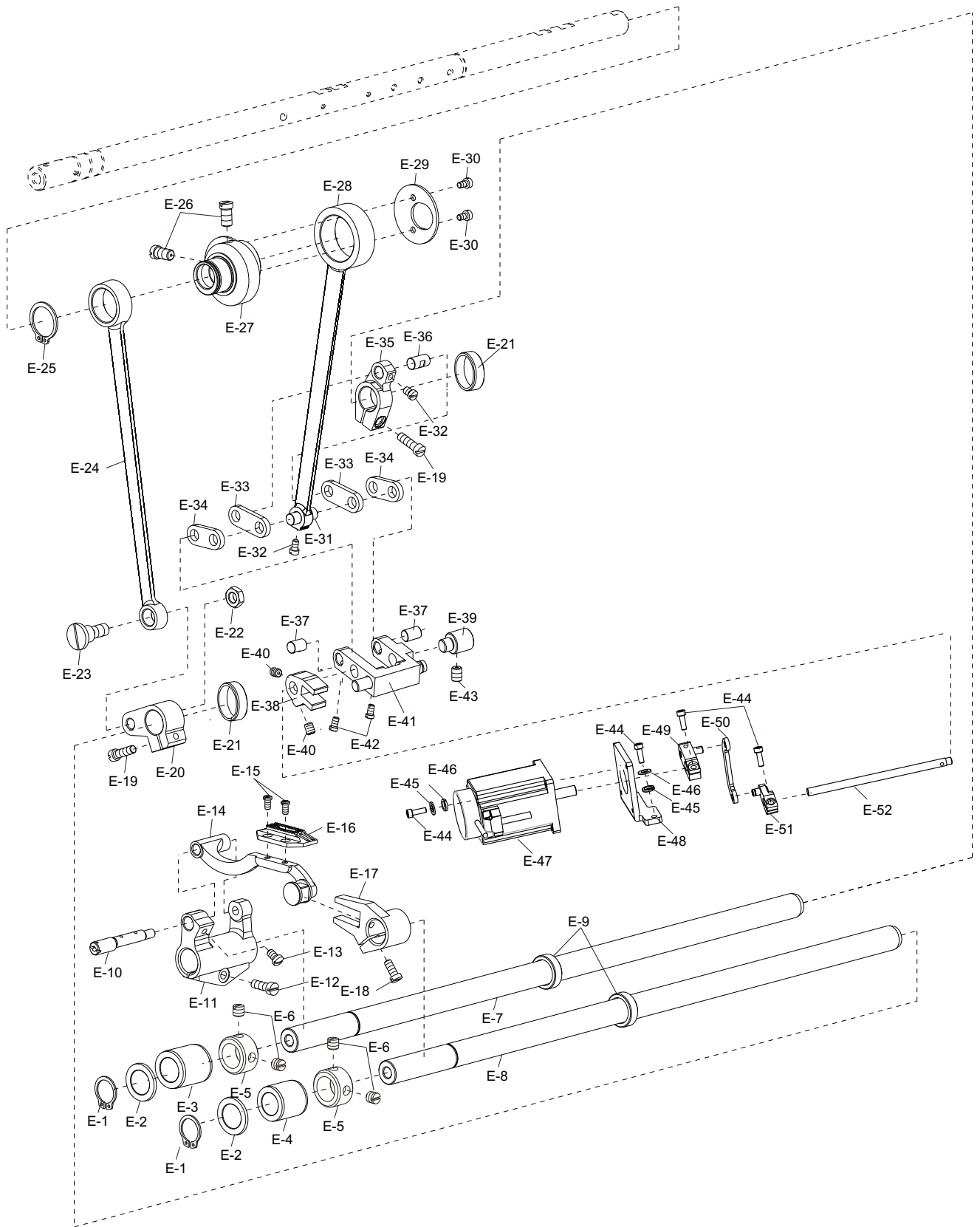

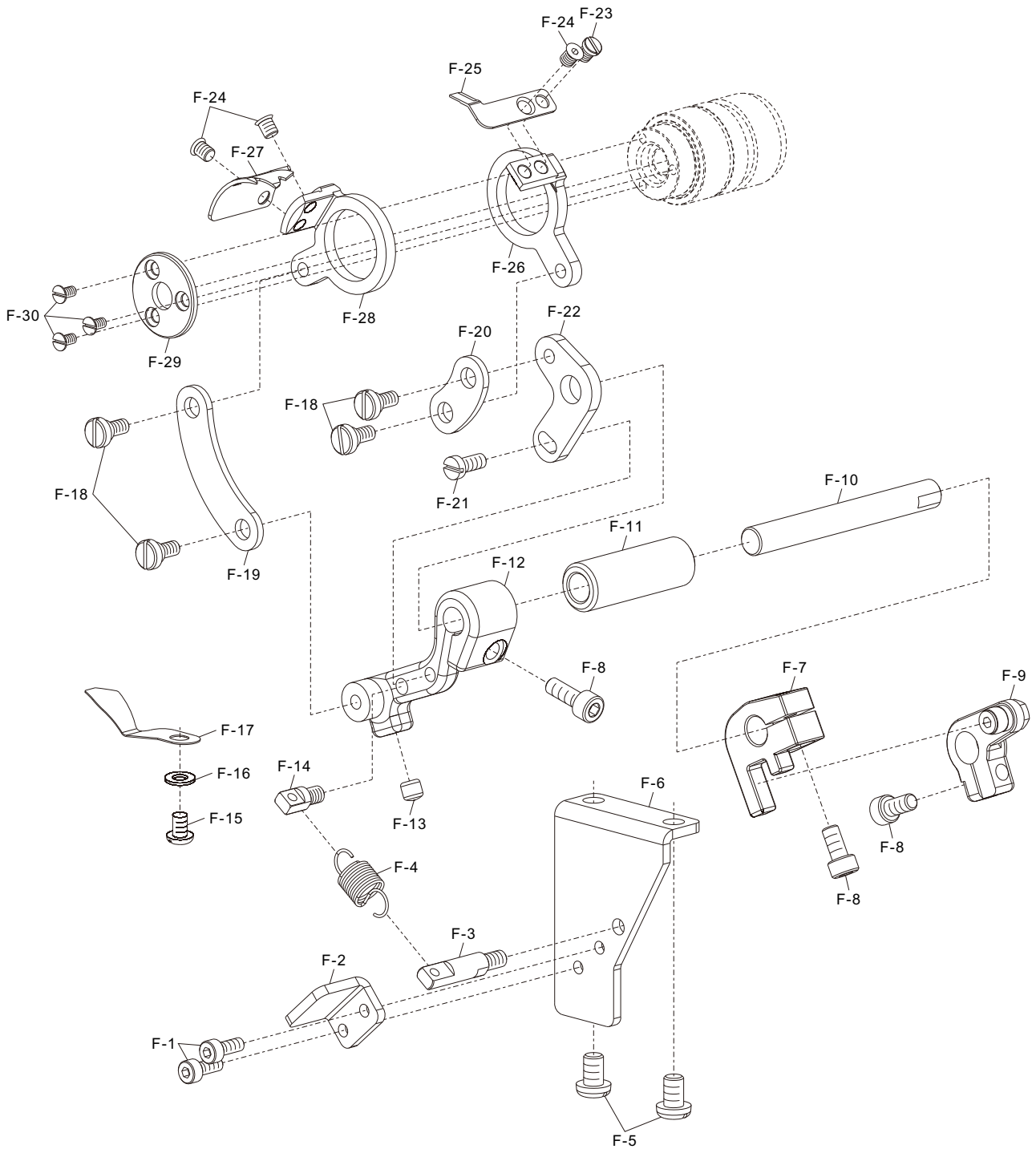

F

剪线分组件

Thread trimmer Components

序号 Ref. No.	件号 Part No.	名称	Name of part	数量 QTY	备注 Remark
F-1	10012752	M4×10螺钉	Screw M4×10	2	
F-2	10065749	限位挡板	Ruler plate	1	
F-3	10065748	复位簧挂销B	Spring pin B	1	
F-4	10065746	复位簧	Spring	1	
F-5	10012142	SM11/64"×40螺钉	Screw SM11/64"×40	2	
F-6	10065751	前支撑板B	Front Shaft sleeve plate	1	
F-7	10065740	剪线曲柄B	Crank B	1	
F-8	10000980	M5×14螺钉	Screw M5×14	3	
F-9	10065737	剪线曲柄组件	Crank ASM.	1	
F-10	10065739	切刀轴	Trimming crank shaft	1	
F-11	10065738	切线轴套	Bushing	1	
F-12	10065756	剪线曲柄C	Crank C	1	
F-13	10011580	切刀驱动曲柄止动块	Block	1	
F-14	10065747	复位簧挂销	Spring pin	1	
F-15	10014474	SM11/64"×40螺钉	Screw SM11/64"×40	1	
F-16	10013154	9×4.5×0.8垫圈	Washer 9×4.5×0.8	1	
F-17	10060697	分线器	Dispart	1	
F-18	10011514	SM11/64"×40螺钉	Screw SM11/64"×40	4	
F-19	10065742	刀轴连杆	Knife shaft crack rod	1	
F-20	10065741	辅助刀刀轴连杆	Knife shaft crack rod	1	
F-21	10012752	M4×10螺钉	Screw M4×10	1	
F-22	10065743	辅助刀轴连杆安装板	Connecting rod mounting plate	1	
F-23	10061665	螺钉	Screw	1	
F-24	10011588	SM11/64"×40螺钉	Screw SM11/64"×40	3	
F-25	10058187	辅助刀	Auxiliary knife	1	
F-26	10065745	辅助刀架	Auxiliary tool holder	1	
F-27	10058184	主动刀	Active knife	1	
F-28	10065744	主动刀架	Active turret	1	
F-29	10013026	刀架压板	Tool holder pressing plate	1	
F-30	10009626	M3×4.35螺钉	Screw M3×4.35	3	

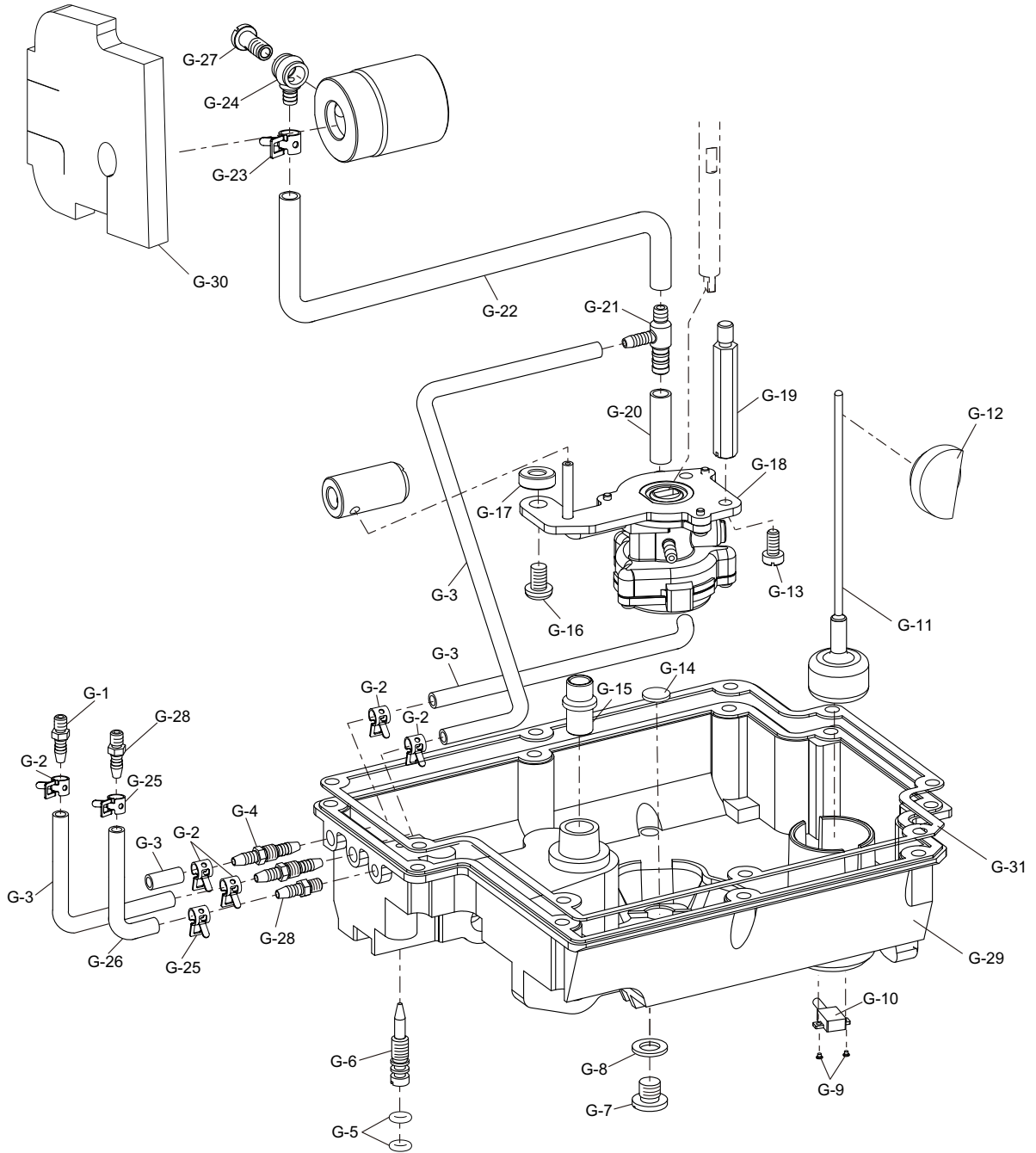



润滑分组件
Lubrication Components

序号 Ref. No.	件号 Part No.	名称	Name of part	数量 QTY	备注 Remark
G-1	10064136	油管接头	Oil connection	1	
G-2	10012160	弹簧	Clamk	5	
G-3	10007800	3×5油管	Oil tube 3×5	650	
G-4	10058103	油管接头	Oil connection	2	
G-5	10000567	3.6×1.8 O形圈	O-ring 3.6×1.8	2	
G-6	10058087	油量调节螺钉	Screw	1	
G-7	10009991	SM5/16"×24螺钉	Screw SM5/16"×24	1	
G-8	10009988	垫圈	Washer	1	
G-9	10066505	螺钉	Screw	2	
G-10	10051706	油量报警开关组件	Oil quantity alarm switch	1	
G-11	10068341	油标组件	Oil pointer ASM.	1	
G-12	10068421	指示窗组件	Indicator ASM.	1	
G-13	10010066	SM11/64"×40螺钉	Screw SM11/64"×40	1	
G-14	10053411	磁铁	Magnet	1	
G-15	10051249	导套	Guide sleeve	1	
G-16	10050422	螺钉	Screw SM15/64"×28	1	
G-17	10059958	垫圈	Washer	1	
G-18	10058201	油泵	Oil pump	1	
G-19	10058276	油泵连接螺柱	Screw	1	
G-20	10032402	φ5.5×φ8油管	Oil tube 5.5×8	30	
G-21	10058212	油管三通	Oil connection	1	
G-22	10007796	4×6 油管	Oil tube 4×6	260	
G-23	10011471	油管夹	Clamk	1	
G-24	10012103	管接头	Oil connection	1	
G-25	10011471	进油短油管夹	Clamk	2	
G-26	10007796	油管	Oil tube	350	
G-27	10012084	螺钉	Screw	1	
G-28	10066949	油管接头	Oil connection	1	
G-29	10058063	齿轮箱盖	Gearbox cover	1	
G-30	10063945	挡油海绵	Oil retaining sponge	1	
G-31	10058100	齿轮箱盖密封垫	Gearbox cover gasket	1	



电控分组件
Drive-by-wire Components

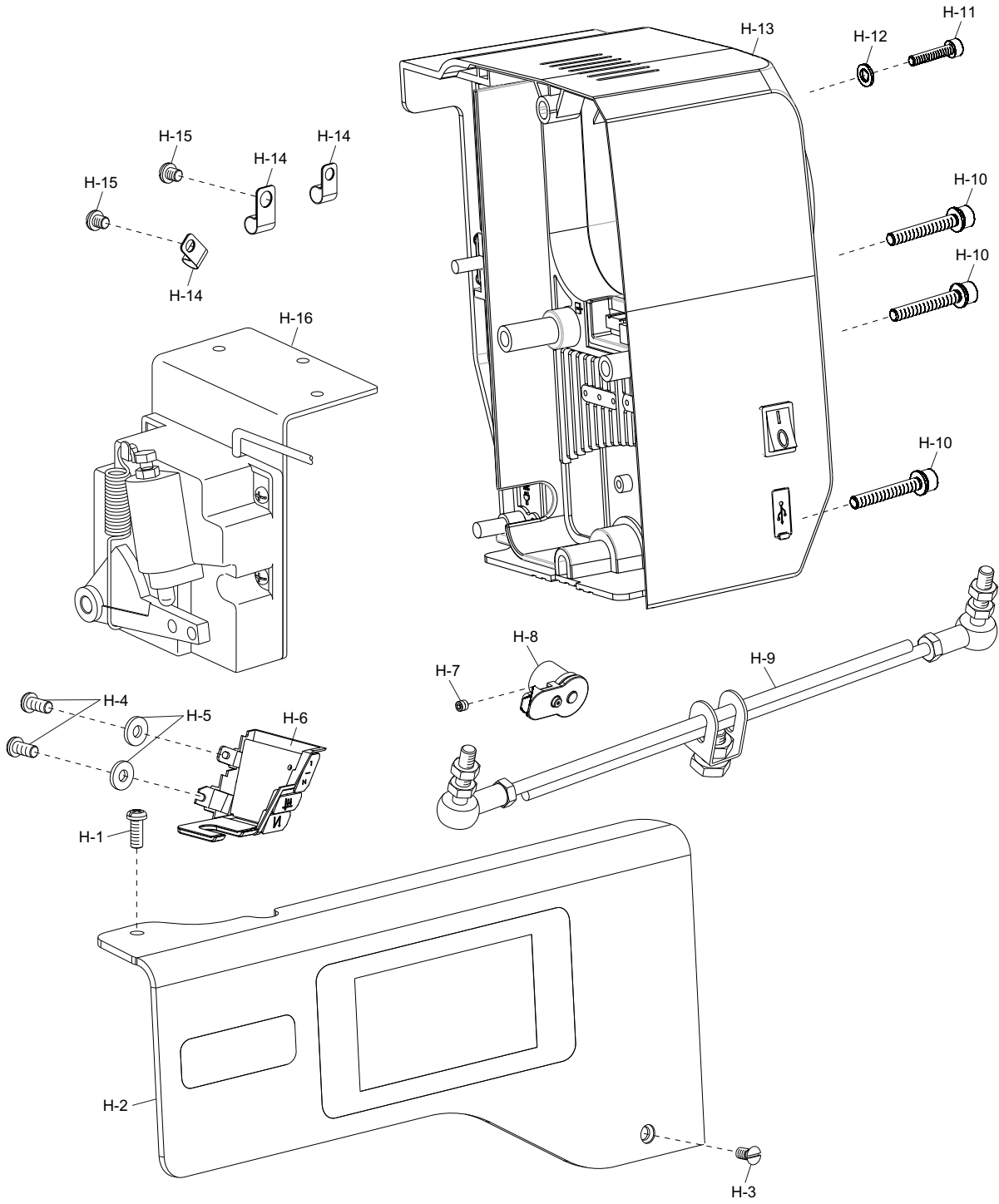



电控分组件
Drive-by-wire Components

序号 Ref. No.	件号 Part No.	名称	Name of part	数量 QTY	备注 Remark
H-1	10063944	SM3/16" ×28螺钉	Screw SM3/16" ×28	1	
H-2	10070391	操作屏组件	Operation screen ASM.	1	
H-3	10043305	SM11/64" ×40螺钉	Screw SM11/64" ×40	1	
H-4	10008934	SM3/16" ×28螺钉	Screw SM3/16" ×28	2	
H-5	10011168	4.8×11.6×1.6垫圈	Washer 4.8×11.6×1.6	2	
H-6	10069056	机头灯部件	Led lamp ASM.	1	
H-7	10009074	M4×4螺钉	Screw M4×4	1	
H-8	10066837	电子夹线器	Electromagnet tension disk	1	
H-9	10002417	踏板连杆组件	Pedal control rod ASM.	1	
H-10	10049837	M5×35螺钉	Screw M5×35	3	
H-11	10012080	M4×20螺钉	Screw M4×20	1	
H-12	10006115	5.3×9×1垫圈	Washer 5.3×9×1	1	
H-13	10068358	A9200L系列一体式电控	Control box	1	
H-14	10062062	电线夹	Cord holder	3	
H-15	10010899	SM3/16" ×28螺钉	Screw SM3/16" ×28	2	
H-16	10031424	踏板组件	Pedal unit ASM.	1	

** 具体内容需向客服咨询
** Specific content need to consult customer service

过线架分组件 Components Of Thread-running Stand

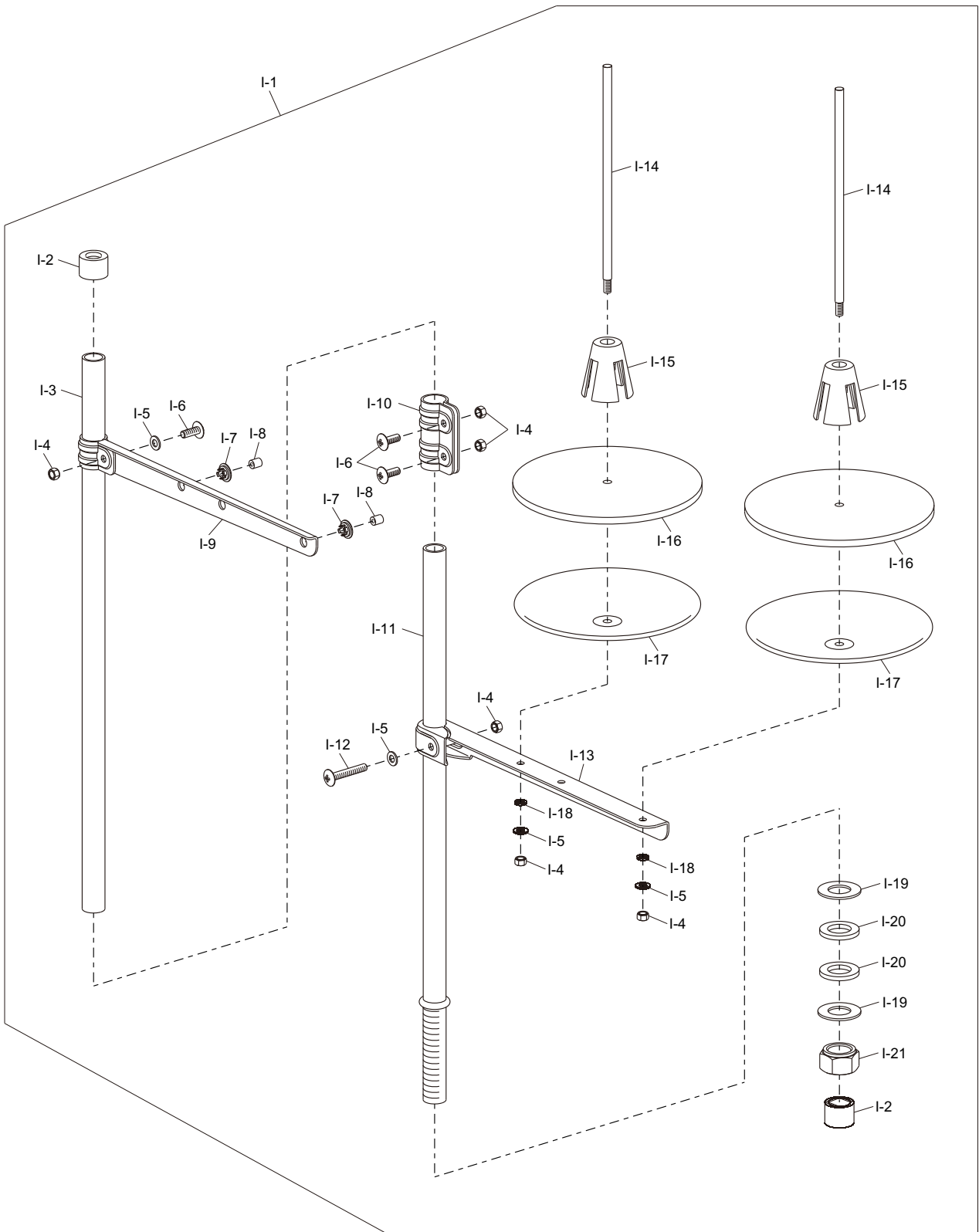

过线架分组件
Components Of Thread-running Stand

序号 Ref. No.	件号 Part No.	名称	Name of part	数量 QTY	备注 Remark
I-1	10007130	二线线架部件	Thread stand ASM.	1	
I-2	10004282	撑管套	Column cap	2	
I-3	10004293	线架上撑管	Column pipe(upper)	1	
I-4	10002953	M5螺母	Nut M5	6	
I-5	10003022	5平垫圈	Washer 5	4	
I-6	10003301	M5×14螺钉	Screw M5×14	3	
I-7	10004285	过线管套	Thread guide bushing	2	
I-8	10004289	过线管	Thread guide pipe	2	
I-9	10004298	上过线架	Thread hanger(upper)	1	
I-10	10004286	撑管夹	Column pipe connector	1	
I-11	10004291	线架下撑管	Column pipe(lower)	1	
I-12	10003312	M5×30螺钉	Screw M5×30	1	
I-13	10004284	下过线架	Thread hanger(lower)	1	
I-14	10004288	线轴	Spool pin	2	
I-15	10004287	线盘塑料压块	Spool cushion	2	
I-16	10004281	线盘软垫	Spool mat	2	
I-17	10004299	线盘	Spool seat disc	2	
I-18	10003077	5弹簧垫圈	Washer 5	2	
I-19	10004290	16×30×1.5垫圈	Washer 16×30×1.5	2	
I-20	10004295	16.5×27.5×3垫圈	Washer 16.5×27.5×3	2	
I-21	10002985	M16螺母	Nut M16	1	

J

附件 Auxiliaries

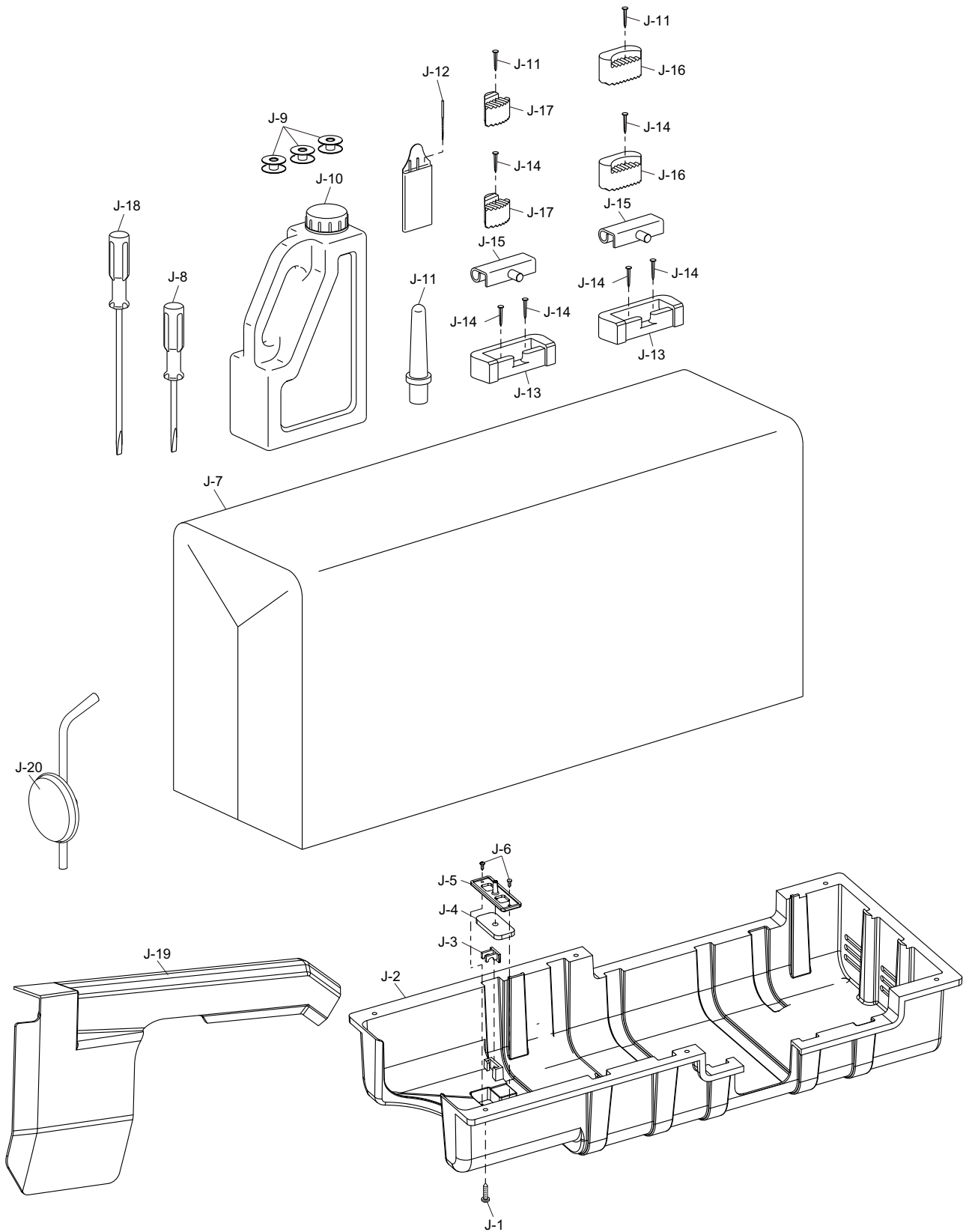

J

附件 Auxiliaries

序号 Ref. No.	件号 Part No.	名称	Name of part	数量 QTY	备注 Remark
J-1	10008323	ST4.2×20螺钉	Screw ST 4.2×20	6	
J-2	10064228	油盘	Oil reservoir	1	
J-3	10051652	回油管固定夹	Holder	1	
J-4	10051707	油盘回油毡	Scavenging felt	1	
J-5	10051651	回油毡压板	Scavenging felt holder	1	
J-6	10003185	ST2.2×6.5螺钉	Screw ST2.2×6.5	2	
J-7	*	机头罩	Head cover	1	
J-8	10013185	小螺丝刀	Screw driver	1	
J-9	10025484	梭芯	Bobbin	3	
J-10	10060847	油箱	Oil box	1	
J-11	10050425	机头支柱	Head pole	1	
J-12	*	DB×1 14#机针	Needle DB×1 14#	3	
J-13	10011041	机头连接钩座	Head connecting hook socket	2	
J-14	10003889	油盘座钉	Nail	8	
J-15	10004466	机头连接钩部件	Head connecting hook	2	
J-16	10064233	油盘座垫	Oil reservoir cushion	2	
J-17	10064234	油盘支座	Oil reservoir seat	2	
J-18	10010994	大螺丝刀	Screw driver	1	
J-19	*	后窗塑料罩	Plastic cover	1	
J-20	10052476	操纵杆部件	Lever components	1	

*请注意:由于产品改进,本手册内容可能会与实际购买的产品略有出入。



浙江中捷缝纫科技有限公司
ZOJE SEWING MACHINE CO., LTD.

地址: 浙江省玉环市大麦屿街道兴港东路198号
ADD: Damaiyu Hing Kong Road no.198, Yuhuan, Zhejiang 317604 China
国内营销中心: Domestic Business Center
Tel: 0576-87338345 87338215 Fax: 0576-87338222
国际营销中心: International Business Center
Tel: +86-576-87333222 87338299 Fax: +86-576-87332702
www.zoje.com E-mail: sales@zoje.com